



Corby Technical School

A-Level Physics

Transition Booklet

What is included:

- Book recommendations
- Guidance on how to make notes
- **Research activities – you must complete at least 2**
- **Pre knowledge topics – you must complete all (answers are at the end)**
- Science Websites
- Science things to do

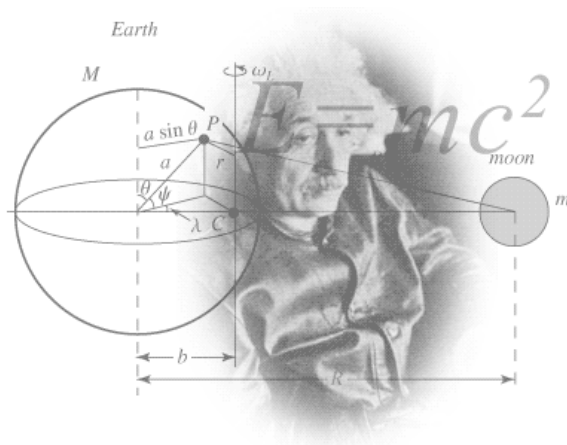

The compulsory activities must be brought with you on the first day back in September and are shown above in GREEN

Isaac Physics is a great website with online quizzes that provide instant feedback. Please join my class using this link

<https://isaacphysics.org/account?authToken=LQHKBN>

Contact Details:

Mr. Godfrey

dgodfrey@corbytechnicalschool.org

Book Recommendations

Below is a selection of books that should appeal to a physicist – someone with an enquiring mind who wants to understand the universe around us. None of the selections are textbooks full of equation work (there will be plenty of time for that!) instead each provides insight to either an application of physics or a new area of study that you will be meeting at A Level for the first time.

1. Surely You're Joking Mr Feynman: Adventures of a Curious Character

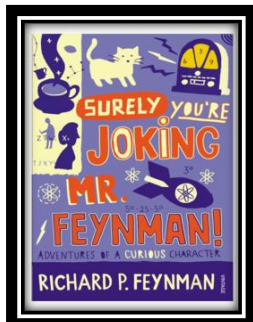

ISBN - 009917331X - Richard Feynman was a Nobel Prize winning Physicist. In my opinion he epitomises what a Physicist is. By reading this books you will get insight into his life's work including the creation of the first atomic bomb and his bongo playing adventures and his work in the field of particle physics.

(Also available on Audio book).

<https://www.waterstones.com/books/search/term/surely+youre+joking+mr+feynman++adventures+of+a+curious+character>

2. Moondust: In Search of the Men Who Fell to Earth

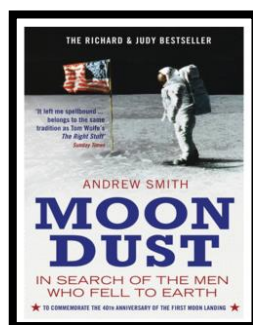

ISBN – 1408802384 - One of the greatest scientific achievements of all time was putting mankind on the surface of the moon. Only 12 men made the trip to the surface, at the time of writing the book only 9 are still with us. The book does an excellent job of using the personal accounts of the 9 remaining astronauts and many others involved in the space program at looking at the whole space-race era, with hopefully a new era of space flight about to begin as we push on to put mankind on Mars in the next couple of decades.

<https://www.waterstones.com/books/search/term/moondust++in+search+of+the+men+who+fell+to+earth>

3. Quantum Theory Cannot Hurt You: Understanding the Mind-Blowing Building Blocks of the Universe

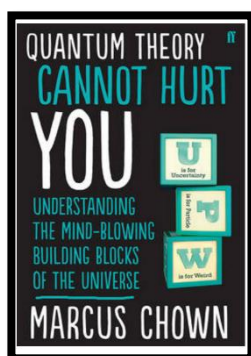

ISBN - 057131502X - Any Physics book by Marcus Chown is an excellent insight into some of the more exotic areas of Physics that require no prior knowledge. In your first year of A-Level study you will meet the quantum world for the first time. This book will fill you with interesting facts and handy analogies to whip out to impress your peers!

<https://www.waterstones.com/book/quantum-theory-cannot-hurt-you/marcus-chown/9780571315024>

4. A Short History of Nearly Everything

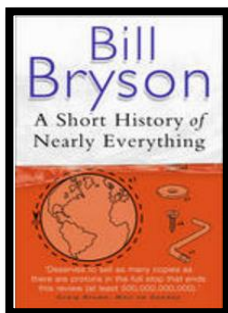

ISBN – 0552997048 - A modern classic. Popular science writing at its best. A Short History of Nearly Everything Bill Bryson's quest to find out everything that has happened from the Big Bang to the rise of civilization - how we got from there, being nothing at all, to here, being us. Hopefully by reading it you will gain an awe-inspiring feeling of how everything in the universe is connected by some fundamental laws.

<https://www.waterstones.com/books/search/term/a+short+history+of+nearly+everything>

5. Thing Explainer: Complicated Stuff in Simple Words

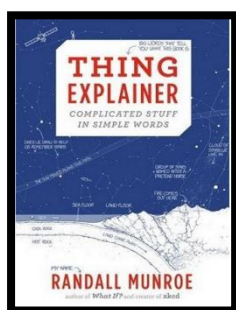

ISBN – 1408802384 - This final recommendation is a bit of a wild-card – a book of illustrated cartoon diagrams that should appeal to the scientific side of everyone. Written by the creator of online comic XTCD (a great source of science humour) is a book of blueprints from everyday objects such as a biro to the Saturn V rocket and an atom bomb, each one meticulously explained BUT only with the most common 1000 words in the English Language. This would be an excellent coffee table book in the home of every scientist.

<https://www.waterstones.com/book/thing-explainer/randall-munroe/9781473620919>

Movie / Video Clip Recommendations

Hopefully you'll get the opportunity to soak up some of the Sun's rays over the summer – synthesising some important Vitamin-D – but if you do get a few rainy days where you're stuck indoors here are some ideas for films to watch or clips to find online.

Science Fictions Films

1. **Moon (2009)**
2. **Gravity (2013)**
3. **Interstellar (2014)**
4. **The Imitation Game (2015)**
5. **The Prestige (2006)**

Online Clips / Series

1. **Minute Physics** – Variety of Physics questions explained simply (in felt tip) in a couple of minutes. Addictive viewing that will have you watching clip after clip – a particular favourite of mine is “Why is the Sky Dark at Night?”

<https://www.youtube.com/user/minutephysics>

2. **Wonders of the Universe / Wonders of the Solar System** – Both available of Netflix as of 17/4/16 – Brian Cox explains the Cosmos using some excellent analogies and wonderful imagery.

3. **Shock and Awe, The Story of Electricity** – A 3 part BBC documentary that is essential viewing if you want to see how our lives have been transformed by the ideas of a few great scientists a little over 100 years ago. The link below takes you to a stream of all three parts joined together but it is best watched in hourly instalments. Don't forget to boo when you see Edison. (alternatively watch any Horizon documentary – loads of choice on Netflix and the I-Player)

<https://www.youtube.com/watch?v=Gtp51eZkwol>

4. **NASA TV** – Online coverage of launches, missions, testing and the ISS. Plenty of clips and links to explore to find out more about applications of Physics in Space technology.

<http://www.nasa.gov/multimedia/nasatv/>

5. **The Fantastic Mr. Feynman** – I recommended the book earlier, I also cannot recommend this 1 hour documentary highly enough. See the life's work of the "great explainer", a fantastic mind that created mischief in all areas of modern Physics.

<https://www.youtube.com/watch?v=LyqleIxTpw>

Research activity

To get the best grades in A Level Physics you will have to get good at completing independent research and making your own notes on difficult topics. Below are links to 5 websites that cover some interesting Physics topics.

Research, reading and note making are essential skills for A level Physics study. For the following task you are going to produce 'Cornell Notes' to summarise your reading.

1. Divide your page into three sections like this

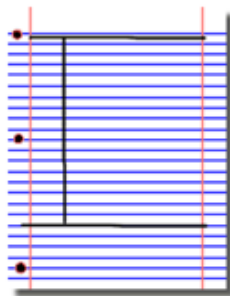

2. Write the name, date and topic at the top of the page



3. Use the large box to make notes. Leave a space between separate idea. Abbreviate where possible.

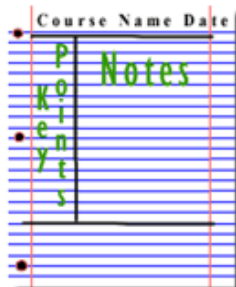

4. Review and identify the key points in the left hand box

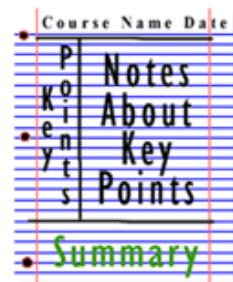

5. Write a summary of the main ideas in the bottom space

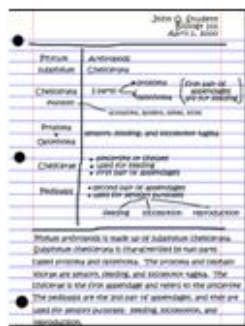

Lesson 1

Pre-

Prefix	Symbol	Power of ten
Nano	n	$\times 10^{-9}$
Micro	μ	$\times 10^{-6}$
Milli	m	$\times 10^{-3}$
Centi	c	$\times 10^{-2}$
Kilo	k	$\times 10^3$
Mega	M	$\times 10^6$
Giga	G	$\times 10^9$

Knowledge Topics

Below are ten topics that are essential foundations for your study of A-Level Physics. Each topic has example questions and links where you can find out more information as you prepare for next year.

Symbols and Prefixes

At A level, unlike GCSE, you need to remember all symbols, units and prefixes. Below is a list of quantities you may have already come across and will be using during your A level course

Quantity	Symbol	Unit
Velocity	v	ms^{-1}

Acceleration	a	ms^{-2}
Time	t	S
Force	F	N
Resistance	R	Ω
Potential difference	V	V
Current	I	A
Energy	E or W	J
Pressure	P	Pa
Momentum	p	kgms^{-1}
Power	P	W
Density	ρ	kgm^{-3}
Charge	Q	C

Solve the following:

1. How many metres in 2.4 km?
2. How many joules in 8.1 MJ?
3. Convert 326 GW into W.
4. Convert 54600 mm into m.
5. How many grams in 240 kg?
6. Convert 0.18 nm into m.
7. Convert 632 nm into m. Express in standard form.
8. Convert 1002 mV into V. Express in standard form.
9. How many eV in 0.511 MeV? Express in standard form.
10. How many m in 11 km? Express in standard form.

Standard Form

At A level quantity will be written in standard form, and it is expected that your answers will be too.

This means answers should be written as $\dots \times 10^y$. E.g. for an answer of 1200kg we would write 1.2×10^3 kg. For more information visit: www.bbc.co.uk/education/guides/zc2hsbk/revision

1. Write 2530 in standard form.
2. Write 280 in standard form.
3. Write 0.77 in standard form.
4. Write 0.0091 in standard form.
5. Write 1 872 000 in standard form.
6. Write 12.2 in standard form.
7. Write 2.4×10^{-2} as a normal number.
8. Write 3.505×10^{-1} as a normal number.
9. Write 8.31×10^{-6} as a normal number.
10. Write 6.002×10^{-2} as a normal number.
11. Write 1.5×10^{-4} as a normal number.
12. Write 4.3×10^3 as a normal number.

Rearranging formulae

This is something you will have done at GCSE and it is crucial you master it for success at A level. For a recap of GCSE watch the following links:

www.khanacademy.org/math/algebra/one-variable-linear-equations/old-school-equations/v/solving-for-a-variable

www.youtube.com/watch?v=_WWgc3ABSj4

Rearrange the following:

1. $E = m \times g \times h$ to find h

2. $Q = I \times t$ to find I

3. $E = \frac{1}{2} m v^2$ to find m

4. $E = \frac{1}{2} m v^2$ to find v

5. $v = u + at$ to find u

6. $v = u + at$ to find a

7. $v^2 = u^2 + 2as$ to find s

8. $v^2 = u^2 + 2as$ to find u

Significant figures

At A level you will be expected to use an appropriate number of significant figures in your answers. The number of significant figures you should use is the same as the number of significant figures in the data you are given. You can never be more precise than the data you are given so if that is given to 3 significant your answer should be too. E.g. Distance = 8.24m, time = 1.23s therefore speed = 6.75m/s

The website below summarises the rules and how to round correctly.

<http://www.purplemath.com/modules/rounding2.htm>

Give the following to 3 significant figures:

1. 3.4527

4. 1.0247

2. 40.691

5. 59.972

3. 0.838991

Calculate the following to a suitable number of significant figures:

6. $63.2/78.1$

7. $39+78+120$

8. $(3.4+3.7+3.2)/3$

9. 0.0256×0.129

10. $592.3/0.1772$

Atomic Structure

You will study nuclear decay in more detail at A level covering the topics of radioactivity and particle physics. In order to explain what happens you need to have a good understanding of the model of the atom. You need to know what the atom is made up of, relative charges and masses and how sub atomic particles are arranged.

The following video explains how the current model was discovered

www.youtube.com/watch?v=wzALbzTdnc8

Describe the model used for the structure of an atom including details of the individual particles that make up an atom and the relative charges and masses of these particles. You may wish to include a diagram and explain how this model was discovered by Rutherford

Lesson 2

Recording Data

Whilst carrying out a practical activity you need to write all your raw results into a table. Don't wait until the end, discard anomalies and then write it up in neat.

Tables should have column heading and units in this format quantity/unit e.g. length /mm

All results in a column should have the same precision and if you have repeated the experiment you should calculate a mean to the same precision as the data.

Below are link to practical handbooks so you can familiarise yourself with expectations.

<http://www.ocr.org.uk/Images/295483-practical-skills-handbook.pdf>

<http://www.ocr.org.uk/Images/295483-practical-skills-handbook.pdf>

Below is a table of results from an experiment where a ball was rolled down a ramp of different lengths. A ruler and stop clock were used.

1) Identify the errors the student has made.

Length/cm	Time			
	Trial 1	Trial 2	Trial 3	Mean
10	1.45	1.48	1.46	1.463
22	2.78	2.72	2.74	2.747
30	4.05	4.01	4.03	4.03
41	5.46	5.47	5.46	5.463
51	7.02	6.96	6.98	6.98
65	8.24	9.68	8.24	8.72
70	9.01	9.02	9.0	9.01

Graphs

After a practical activity the next step is to draw a graph that will be useful to you. Drawing a graph is a skill you should be familiar with already but you need to be extremely vigilant at A level. Before you draw your graph to need to identify a suitable scale to draw taking the following into consideration:

- the maximum and minimum values of each variable
- whether 0.0 should be included as a data point; graphs don't need to show the origin, a false origin can be used if your data doesn't start near zero.
- the plots should cover at least half of the grid supplied for the graph.
- the axes should use a sensible scale e.g. multiples of 1,2, 5 etc)

Identify how the following graphs could be improved

Graph 1

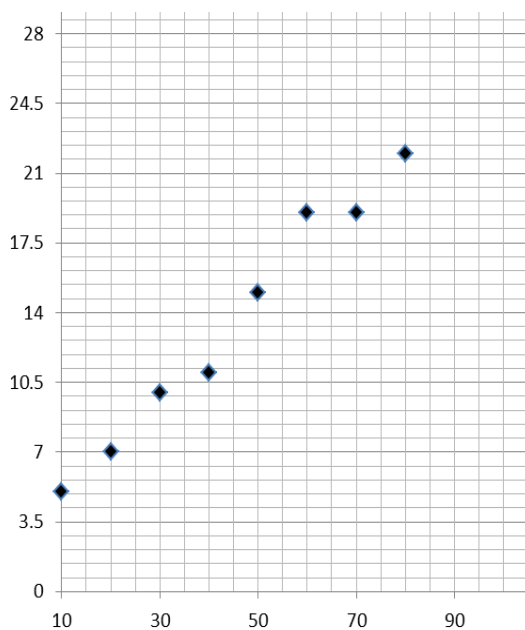

Graph 2

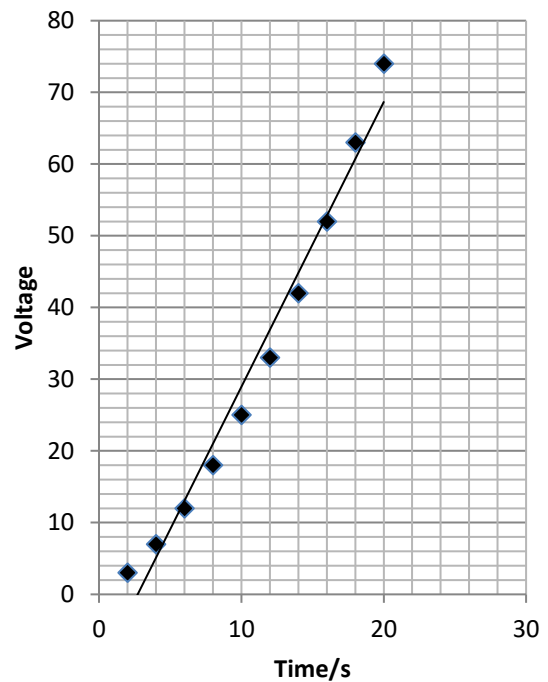

Lesson 3

Forces and Motion

At GCSE you studied forces and motion and at A level you will explore this topic in more detail so it is essential you have a good understanding of the content covered at GCSE. You will be expected to describe, explain and carry calculations concerning the motion of objects. The websites below cover Newton's laws of motion and have links to these in action.

<http://www.physicsclassroom.com/Physics-Tutorial/Newton-s-Laws>

<http://www.sciencechannel.com/games-and-interactives/newtons-laws-of-motion-interactive/>

Sketch a velocity-time graph showing the journey of a skydiver after leaving the plane to reaching the ground.

Mark on terminal velocity.

Lesson 4

At A level you will learn more about how current and voltage behave in different circuits containing different components. You should be familiar with current and voltage rules in a series and parallel circuit as well as calculating the resistance of a device.

<http://www.allaboutcircuits.com/textbook/direct-current/chpt-1/electric-circuits/>

<http://www.physicsclassroom.com/class/circuits>

1a) Add the missing ammeter readings on the circuits below.

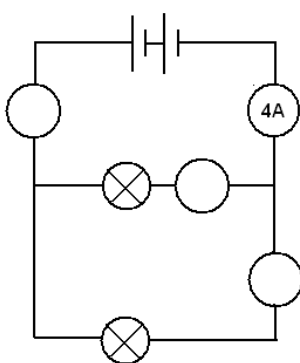
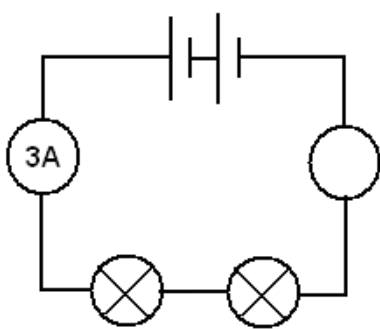

b) Explain why the second circuit has more current flowing than the first.

2) Add the missing potential differences to the following circuits

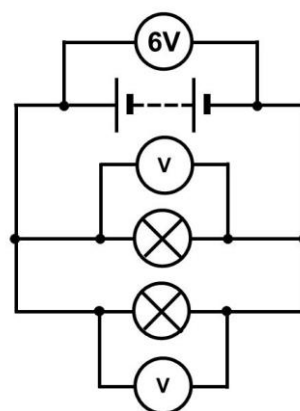
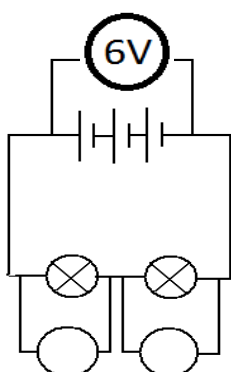

Lesson 5

Waves

You have studied different types of waves and used the wave equation to calculate speed, frequency and wavelength. You will also have studied reflection and refraction.

Use the following links to review this topic.

<http://www.bbc.co.uk/education/clips/zb7gkqt>

<https://www.khanacademy.org/science/physics/mechanical-waves-and-sound/mechanical-waves/v/introduction-to-waves>

<https://www.khanacademy.org/science/physics/mechanical-waves-and-sound/mechanical-waves/v/introduction-to-waves>

- 1) Draw a diagram showing the refraction of a wave through a rectangular glass block. Explain why the ray of light takes this path.

- 2) Describe the difference between a longitudinal and transverse waves and give an example of each

- 3) Draw a wave and label the wavelength and amplitude

Pre-Knowledge Topics Answers:

Symbols and prefixes

1. 2400
2. 8 100 000
3. 326 000 000 000
4. 54.6
5. 240 000
6. 1.8×10^{-8}
7. 6.32×10^{-7}
8. 1.002
9. 5.11×10^{-5}
10. 1.1×10^4

Standard Form:

1. 2.53
2. 2.8
3. 7.7
4. 9.1
5. 1.872
6. 1.22
7. 2400
8. 35.05
9. 8 310 000
10. 600.2
11. 0.00015
12. 4300

Rearranging formulae

1. $h = E / (m \times g)$
2. $I = Q/t$
3. $m = (2 \times E)/v^2$ or $E/(0.5 \times v^2)$
4. $v = \sqrt{(2 \times E)/m}$
5. $u = v - at$
6. $a = (v-u)/t$
7. $s = (v^2 - u^2) / 2a$
8. $u = \sqrt{v^2 - 2as}$

Significant figures

1. 3.35
2. 40.7
3. 0.839
4. 1.02
5. 60.0
6. 0.809
7. 237
8. 3.4
9. 0.00330
10. 3343

Atomic Structure

contains protons, neutrons and electrons

Relative charge:

protons are positive (+1)

electrons are negative (-1)

neutrons are uncharged (0)

Relative mass:

proton 1

neutron 1

electron (about) $1/2000$

protons and neutrons make up the nucleus

the nucleus is positively charged

electrons orbit the nucleus at a relatively large distance from the nucleus

most of the atom is empty space

nucleus occupies a very small fraction of the volume of the atom

most of the mass of the atom is contained in the nucleus

total number of protons in the nucleus equals the total number of electrons orbiting it in an atom

Recording data

Time should have a unit next to it

Length can be measured to the nearest mm so should be 10.0, 22.0 etc

Length 65 trial 2 is an anomaly and should have been excluded from the mean

All mean values should be to 2 decimal places

Mean of length 61 should be 6.99 (rounding error)

Graphs

Graph 1:

Axis need labels

Point should be x not dots

Line of best fit is needed

y axis is a difficult scale

x axis could have begun at zero so the y-intercept could be found

Graph 2:

y-axis needs a unit

curve of best fit needed not a straight line

Point should be x not dots

Forces and motion

Graph to show acceleration up to a constant speed (labelled terminal velocity). Rate of acceleration should be decreasing. Then a large decrease in velocity over a short period of time (parachute opens), then a decreasing rate of deceleration to a constant speed (labelled terminal velocity)

Electricity

1a) Series: 3A, Parallel top to bottom: 4A,2A,2A

b) Less resistance in the parallel circuit. Link to $R=V/I$. Less resistance means higher current.

2) Series: 3V, 3V, Parallel: 6V 6V

Waves

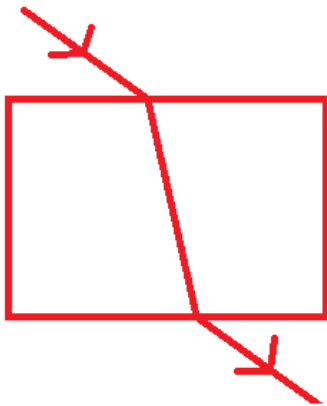

1) When light enters a more optically dense material it slows down and therefore bends towards the normal. The opposite happened when it leaves an optically dense material.

2) A longitudinal wave oscillates parallel to the direction of energy transfer (e.g. sound). A transverse waves oscillated perpendicular to the direction of energy transfer (e.g. light)

3)

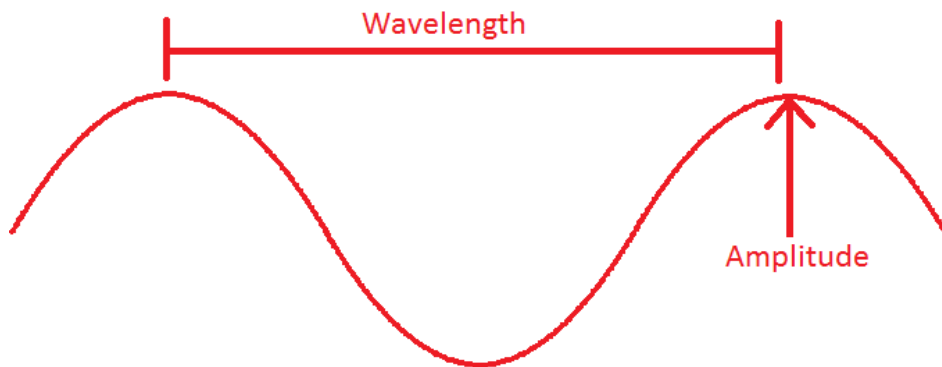

Ideas for Day Trips

Here are some suggestions for some physics-themed days out for you to enjoy over the summer break. Try and have some fun as you prepare for two tough but rewarding years ahead!

Northern England and Scotland

1. **Jodrell Bank Observatory** – Cheshire – one of the largest moveable radio telescopes in the world and the location of the filming of the BBC's Stargazing Live. The site has both indoor and outdoor activities.
2. **MOSI** – Manchester – Massive free museum showing how science helped Britain lead the way through the industrial revolution. Contains hands on exhibits and displays and often host regular travelling exhibitions.
3. **Liverpool World Museum / Spaceport** – Liverpool/Wirral – Start the day off at an excellent family science museum with a top floor dedicated to astronomy including a planetarium. Take the ferry cross the Mersey to another family friendly museum dedicated to spaceflight.
4. **Kielder Observatory** – Northumberland – Book ahead at this popular observatory in the midst of the darkest night skies the UK has to offer. Regular tours and opportunities to view the stars through professional telescopes take place on a nightly basis.
5. **Glasgow Science Centre** - The Centre is home to hundreds of interactive exhibits throughout the three engaging floors

The Midlands and Wales

1. **Electric Mountain** – Snowdonia – Set against a mountainous backdrop is a working pumped storage power station. Take a tour deep into the heart of the mountain and see the turbines spring into action to meet our ever increasing demand for electricity. Take a stroll up on of the UKs highest peaks in the afternoon.
2. **National Space Centre** – Leicester - With six interactive galleries, the UK's largest planetarium, unique 3D Simulator experience, the award-winning National Space Centre in Leicester is an out of this world visitor attraction
3. **Alton Towers** – Staffordshire – Treat yourself to a go on a few rollercoasters whilst discussing Newton's Laws. You may want to download and take these handy rollercoaster physics notes with you <http://www.explainthatstuff.com/rollercoasters.html>

Southern England

1. **Royal Observatory** – London - Visit the Royal Observatory Greenwich to stand on the historic Prime Meridian of the World, see the home of Greenwich Mean Time (GMT), and explore your place in the universe at London's only planetarium.
2. **Herschel Museum of Astronomy** – Bath – As you walk around the picturesque Roman city – take an hour or two out at the home of one of the great scientists – discoverer of Infra-red radiation and Uranus.
3. **@Bristol** – Bristol - home to the UK's only 3D Planetarium and one of the biggest science centres.
4. **The Royal Institution** – London – The birthplace of many important ideas of modern physics, including Michael Faraday's lectures on electricity. Now home to the RI Christmas lectures and many exhibits of science history.